



INDIANA DEPARTMENT OF TRANSPORTATION

Driving Indiana's Economic Growth

Design Memorandum No. 21-25

December 30, 2021

TO: All Design, Operations, and District Personnel, and Consultants

FROM: /s/Athar Khan
Athar Khan
Director, Geotechnical Engineering Division
Engineering Department

SUBJECT: Mechanically Stabilized Earth (MSE) Walls

REVISES: *Indiana Design Manual (IDM) Chapter 14, Sections 14-2.01(07), 14-2.01(12), 14-2.04(06), 14-2.04(09), 14-2.05(05)*
Indiana Design Manual (IDM) Chapter 17, Figure 17-5C
Indiana Design Manual (IDM) Chapter 402, Section 402-6.02(02)
Indiana Design Manual (IDM) Chapter 409, Figure 409-2G
Indiana Design Manual (IDM) Chapter 410, Section 410-5.01(06) and Figure 410-5(O)C
Editable Document: MSE Wall Design Review Checklist

SUPERSEDES: 21-02 Mechanically Stabilized Earth (MSE) Walls

EFFECTIVE: Stage 2 Submittals on or after December 30, 2021

Design Memo 21-02 (later incorporated into IDM) was issued to introduce MSE Wall Feasibility Reviews at Stage 1 and Stage 3 of the project development process. This memo provides flexibility; if sufficient information is available; to complete the final feasibility review at Stage 2 instead of Stage 3. These revisions were incorporated in the pertinent sections of *Indiana Design Manual*, Chapter 14.

In addition, Chapter 402 of the *Indiana Design Manual* has been revised to update the minimum distance between the back of the MSE Wall panel and the center of the pile to 4 times the diameter of the pile.

Furthermore, Chapter 410 of the IDM has been updated and revised to include requirements for utilities placement under the MSE walls and culverts placement through the MSE walls. Editable document titled [MSE Wall Design Review Checklist](#) has also been updated to reflect these revisions in IDM.

A summary of IDM and MSE Wall Design Review Checklist revisions can be found at the end of this memo.

For question related to this design memo please contact Geotechnical Engineering Division: MSEWallShopDrawings@indot.IN.gov.

IDM Revision Overview

IDM Item	Title	Revision
Section 14-2.01(07) Section 14-2.01(12) Section 14-2.04(06) Section 14-2.04(09) Section 14-2.05(05)	Stage 2 Review Submission Stage 3 Review Submission Stage 2 Review Submission Stage 3 Review Submission Stage 3 Review Submission	A check list for MSE wall design has been updated and was added as an Editable Document.
Section 402-6.02(02)	Alignment	Updates the minimum distance between the back of the MSE Wall panel and the center of the pile to 4 times the diameter of the pile.
Section 410-5.01(06)	Design Criteria	Includes requirements for utilities placement under the MSE walls and culverts placement through the MSE walls.
Figure 17-5C	MSE Retaining Wall Earthwork Quantities Limits	Updates show the correct minimum depth of embedment of 3 feet.
Figure 409-2G	End Bent Placed Behind MSE Wall	Includes the updated requirements in Section 410-5.01(06) and corner details when MSEW is placed parallel to the bridge approach roadway.
Figure 410-5(0)C	Typical MSE Wall Cross Section	Includes the requirement to use Geotextile Type IB for underdrains.
Editable Document	MSE Wall Design Review Checklist	Updates the relevant sections in accordance with the revised section of Indiana Design Manual.

Chapter 14 Revisions

14-2.01(07) Stage 2 Review Submission [Rev. Apr. 2020, Mar. 2021, Dec. 2021]

Plans should be approximately 55% complete at this stage.

Plans for this submittal should be close to their final form and should be legible and consistent with the quality desired for public viewing at a public-information meeting, if required. The designer should review the *INDOT Typical Plan Sheets* document to determine what information should be included on each sheet. If the project includes traffic signal(s), signing, or lighting details a separate set of plans should be submitted into ERMS for traffic review in accordance with Section 14-1.02(09).

Review the following sheets and information for quality assurance and include them with this submission.

1. Previous Reviews. Include the marked-up plans from the Stage One submittal, changes made from the Preliminary Field Check meeting, and comments from the construction review with this submission. Include revisions to the plans due to Geotechnical Report recommendations, if completed. Include responses to preliminary field check questions.
2. Conformance. The designer should check the plans for conformance with the Level One controlling design criteria listed in Section 40-8.02(01). Apparent or possible design exceptions should be identified. Discrepancies from the Level Two design criteria listed in Section 40-8.02(02) should also be identified. The required documentation for all Level One and Level Two design exceptions should be prepared.
3. Index and Title Sheet. Finalize the title sheet and index sheet for the roadway plans.
4. Plat Sheets. Plat sheets, if required, should be consistent with the plans and finalized.
5. Traffic Maintenance Details. Finalize all maintenance of traffic details including pedestrian and bicycle maintenance of traffic where required in accordance with Section 503-3.0.
6. Plan and Profile Sheets. Right of way should be finalized and consistent with the detail sheets. Additional information to be shown is as follows:
 - a. drainage features (e.g., storm sewers, pipe structures, ditch grades, preliminary inlet spacing for storm-sewer trunk line design, etc.) and proposed drainage notes; and

- b. permanent erosion protection, including paved side ditches, riprap, and sodding limits.
 - c. Finalize curb ramps, sidewalks, bicycle lanes, etc., if not shown on the Details sheets.
7. Structure Data Table. The table should be in a preliminary form and should include structure numbers and locations.
8. Approach Table. The table should be in a preliminary form and should include approach geometrics.
9. Cross Sections.
10. Design Information. Information to be included is as follows:
 - a. hydraulics and storm-sewer calculations, signed and sealed by a professional engineer licensed in Indiana; and
 - b. cost estimate. The preliminary cost estimate should be refined for the major pay items with percentages shown for the minor pay items.
11. Level One Checklists and Design Computations. If there are no changes to the plans which affect Level One criteria since the prior submission, it is acceptable to copy the previous Level One Checklist and add a statement that no changes have been made to the plans that affect Level One criteria. The statement should be initialed and dated for the current submission. The plans must be developed to satisfy the PDP Manual's Project Constructability Review 2.

The designer should submit a Level One checklist, including computations for the mainline, each S-line, and each traffic-maintenance phase. The designer should include computations for the required intersection sight distance at each public road, including each local-service road or frontage road within the project limits. The designer should also submit documentation of the intersection sight distance provided at each public road. This requirement also applies to the traffic-maintenance phases.
12. INDOT All Project Commitments Report. This should include all known resolutions.
13. Initiate Stormwater Quality Manager Determination. The designer should Provide initial Stormwater Quality Manager level recommendation on Transmittal Letter with brief explanation. The SWQM level starts at Level 1 and will be elevated to Level 2 based on

meeting either the primary or secondary categories. SWQM Level determination guidance is available from the Department's [Design Manual Editable Documents](#), under Environmental.

14. Draft TMP Report for Significant Projects. The following documents should be included in the draft TMP Report unless it is not required. Where a document is not required, reasoning should be noted.
 1.
 - a. TMP Team. The designer should provide a list of the TMP Team members and contact information, including all stakeholders, see Section 503-2.04.
 - b. TMP meeting minutes or other correspondence.
 - c. Determination of Significant Work Zone Impacts, see Section 503-2.02.
 - d. Approved Traffic Control Strategy memo, see Section 503-2.05(02),
 - e. Draft IHCP exception request, where required, see Section 503-3.02,
 - f. Detour Worksheet (Non-Interstate or Interstate), Design Manual Editable Documents Webpage, under Traffic Maintenance (MOT),
 - g. Crossover and Runaround Viability Worksheet, Design Manual Editable Documents Webpage, under Traffic Maintenance (MOT),
 - h. Contract Provision Strategies, see Section 503-2.06,
 - i. Temporary Signal Type Determination, Design Manual Editable Documents Webpage, under Traffic Maintenance (MOT),
 - j. Draft Programming Information for Portable Changeable Message Sign, Design Manual Editable Documents Webpage, under Traffic Maintenance (MOT)
 - k. Final design exception approvals,
 - l. Final mitigation measures, see Section 503-4.0.
15. Traffic Control Plan Checklist. See [Section 14-1.02\(03\)](#) for Traffic Control Plan Checklist information.
16. MSE Wall Design Review Checklist. If the project includes MSE walls, and the geotechnical soils investigations and the retaining wall plan sheets have been finalized, the relevant plan sheets and the completed MSE Wall Design Review checklist may be submitted to the Geotechnical Engineering Division for review at MSEWallShopDrawings@indot.IN.gov at this stage. The checklist is available for download from the Department's [Design Manual Editable Documents](#), under Geotechnical.

14-2.01(12) Stage 3 Review Submission [Rev. Feb. 2012, Feb. 2021, Mar. 2021, Jun. 2021, Dec. 2021]

Plans should be approximately 95% complete at this stage.

The purpose of this submittal is to ensure that the plans are complete and satisfy the criteria provided in the Engineering Assessment studies. The following should be completed and reviewed for quality assurance. Include responses to Final Field Check questions.

If the project includes traffic signal(s), signing, or lighting details a separate set of plans should be submitted into ERMS for traffic review in accordance with Section 14-1.02(09).

For a project that requires only a Stage 3 Submission, all documentation required for Stages 1 through the Final Field Check Meeting, if not previously submitted, must be included in the Stage 3 submittal. Documentation will include the abbreviated Engineer's Assessment, geotechnical report, and pavement-design approval.

1. Previous Reviews. Include the marked-up plans from the Stage 2 submittal and changes made from the Final Field Check meeting with this submission. Right-of-way changes made after Final Right-of-Way Plans are submitted should be processed in accordance with Section 85-3.03.
2. Conformance. Review the plans for conformance with the Level One controlling design criteria listed in Section 40-8.02(01) and indicate approved dates for design exceptions.
3. Plans Set. If a Final Field Check meeting is not held at the discretion of the project manager, all of the milestone requirements should still be review and incorporated.
 - a. Erosion Control Plan. Include the completed set.
 - b. Road Summary Sheets. The content and requirements are described below. For a large project for which the standard-sized Summary tables cannot accommodate all of the items, multiple custom Summary sheets should be used to accommodate all the necessary information. The Summary sheet frames, in DGN and XLS format,

can be downloaded from http://www.in.gov/indot/div/cad/v8i_downloads.htm. The Pavement Quantities and Approach Table, Structure Data, Paved Side Ditch Summary, Riprap Ditch and Sodding Table, Underdrain Table, Guardrail Summary Table with guardrail-related pay items, Sign Summary Table, Pipe Material Selection, and mailbox approaches information including required HMA quantities should be completed.

- c. Cross Sections. The project engineer or supervisor will require the elevations for existing cross sections in order to calculate the final earthwork quantities.

If the project was designed from an electronic survey, the design calculations should include a data table created from the electronic cross-sections which indicates all existing cross-section elevations.

An example data table is shown as Figure [14-2A](#).

4. Quantities. Finalize all quantities.
5. Reports. Ensure that the recommendations from the Geotechnical Report and other reports regarding peat, hazardous waste, special waste, etc. have been incorporated into the plans, specifications, and cost estimate.
6. Cost Estimate. Conduct a detailed review to ensure that all necessary pay items have been included. Finalize the construction cost estimate using Estimator.
7. Level One Checklists and Design Computations. If there are no changes to the plans which affect Level One criteria since the prior submission, it is acceptable to copy the previous Level One Checklist and add a statement that no changes have been made to the plans that affect Level One criteria. The statement should be initialed and dated for the current submission.
8. Special Provisions and Special Provision Menus. Compile all USPs submitted via SharePoint into a single Word document and submit via ERMS. This is to aid the Design Reviewer in viewing a comprehensive Stage 3 submission and does not replace the SharePoint process. See Chapter 19 for additional information on the USP submittal and review process.

Compile all completed contract-specific recurring special provisions into a single Word document.

Complete the unique and recurring special provisions menus.

9. Rule 5. If required, and not previously submitted in accordance with Section 9-1.02, complete the Rule 5 Submission as described in Chapter 205.

10. Underground Storage Tanks Removal. If this work is required, the designer should coordinate such activity with the Office of Environmental Services manager. The designer should complete Figure [14-2B](#), Underground Storage Tanks Removal information request. If a final field check is not required, the coordination should take place six months prior to the Ready for Contracts date.

This coordination is to ensure that required pay items such as excavation and handling of contaminated soil are included in the contract.

11. INDOT All Project Commitments Report. This should include all known resolutions.

12. Proprietary Material. If a proprietary material is specified that is either not listed the Department's [Approved Materials List](#) or is on Department's list of [Approved Programmatic Proprietary Material](#), the designer must submit for approval a certification or a public-interest finding request. Editable versions of these documents appear on the Department's website, at <http://www.in.gov/dot/div/contracts/design/dmforms/>, under Proprietary Material.

13. Environmental Consultation Form. Summarization 7-3C should be completed at this submission. An editable version of this document appears on the Department's website, at www.in.gov/dot/div/contracts/design/dmforms/, under Environmental.

14. MSE Wall Design Review Checklist. If the project includes MSE walls and the retaining wall plans were not finalized and submitted at Stage 2 along with the completed MSE Wall Design Review checklist (or the Stage 2 review comments have not been addressed to the satisfaction of Geotechnical Engineering Division), the relevant plan sheets and the completed MSE Wall Design Review checklist are required to be submitted to the Geotechnical Engineering Division for review at MSEWallShopDrawings@indot.IN.gov. The checklist is available for download from the Department's [Design Manual Editable Documents](#), under Geotechnical.

15. Traffic Control Plan Checklist. See [Section 14-1.02\(03\)](#) for Traffic Control Plan Checklist information.
16. Final Approved IHCP Request, if required. See Section 503-3.02.
17. Final TMP Report for Significant Projects. See Section 503-2.0

14-2.04(06) Stage 2 Review Submission [Rev. May 2017, Apr. 2020, Mar. 2021, Dec.2021]

Plans should be approximately 50% complete at this stage.

Plans for this submittal should be close to their final form. The plans sheets for this submittal should be legible and consistent with the quality desired for public viewing. The right-of-way plans should be consistent with the requirements of Chapter 85.

If the project includes traffic signal(s), signing, or lighting details a separate set of plans should be submitted into ERMS for traffic review in accordance with Section 14-1.02(09).

The following sheets and information must be reviewed for quality assurance and should be included with this submission.

1. Previous Reviews. This submission should include the following:
 - a. marked-up plans from the previous submission;
 - b. document changes made from the Preliminary Field Check meeting;
 - c. revisions to the plans due to the Geotechnical Report, if completed; and
 - d. responses to field check questions.
2. Conformance. Review the plans for conformance with the Level One controlling design criteria listed in Section 40-8.02(01) and indicate apparent or possible design exceptions. Indicate discrepancies from the Level Two design criteria listed in Section 40-8.02(02). The required documentation for all Level One and Level Two design exceptions should be prepared.

3. Title and Index Sheets. Finalize the title sheet for right-of-way plans, and include the right-of-way index in a separate sheet 2.

4. Plat Sheets. All plat sheets, if required should be consistent with the plans and finalized.

Traffic Maintenance Details. Finalize all maintenance of traffic details including pedestrian and bicycle maintenance of traffic where required in accordance with Section 503-3.01.

5. Soil Borings Sheet. Ensure the information is accurate from the Geotechnical Report. Each boring log should include an elevation at each break in the soil strata. The elevations should be shown along the vertical grid so that the elevation of each soil sample can be ascertained. Logs for roadway borings should not be included on this sheet.

**** PRACTICE POINTER ****

Copies of the boring logs included in the Geotechnical Report may be scanned and placed onto the Soil Borings sheet, provided they are still legible once the plans are reduced to half-size.

6. Road Plan and Profile Sheets. Right-of-way should be finalized and consistent with the Details sheets. The sheets should include the information as follows:

- a. drainage features (e.g., storm sewers, pipe structures, ditch grades, preliminary inlet spacing for storm-sewer trunk line design, etc.) and proposed drainage notes; and
- b. permanent erosion protection, including paved side ditches, riprap, and sodding limits.
- c. Finalize curb ramps, sidewalks, bicycle lanes, etc., if not shown on the Details Sheets.

7. Layout Sheet. The Layout sheet should be essentially complete.

8. General Plan Sheet. The General Plan sheet should be essentially complete.

9. Road Summary Sheet.
 - a. Structure data table is in preliminary form and should include structure numbers and locations.
 - b. Approach table is in preliminary form and should include the approaches' design information.

10. Cross Sections.

11. Design Information. In addition to the construction plans, this submittal should include an updated cost estimate. The Department's cost-estimating procedures should be used for the preliminary construction cost estimate; see Chapter Twenty. Quantities will consist only of major pay items with a percentage added to consider minor pay items. If practical, the traffic-related pay items should be segregated.

12. Level One Checklists and Design Computations. If there are no changes to the plans which affect Level One criteria since the prior submission, it is acceptable to copy the previous Level One Checklist, and add a statement that no changes have been made to the plans that affect Level One criteria. The statement should be initialed and dated for the current submission.

The designer should submit a Level One Checklist, including computations for the mainline, each S-line, and each traffic-maintenance phase. The designer should include computations for the required intersection sight distance at each public road, including each local-service road or frontage road within the project limits. The designer should also submit documentation of the intersection sight distance provided at each public road. This requirement also applies to the traffic-maintenance phases.

13. Permit Information. This should be provided as required.

14. INDOT All Project Commitments Report. This should include all known resolutions.

15. Initiate Stormwater Quality Manager Determination. The designer should Provide initial Stormwater Quality Manager level recommendation on Transmittal Letter with brief explanation. The SWQM level starts at Level 1 and will be elevated to Level 2 based on meeting either the primary or secondary categories. SWQM Level determination guidance is available from the Department's Design Manual Editable Documents at <http://www.in.gov/dot/div/contracts/design/dmforms/>, under Environmental.
16. Draft TMP Report for Significant Projects. The following documents should be included in the draft TMP Report unless not it is not required. Where a document is not required, reasoning should be noted.
 - a. TMP Team. The designer should provide a list of the TMP Team members and contact information, including all stakeholders, see Section 503-2.04.
 - b. TMP meeting minutes or other correspondence.
 - c. Determination of Significant Work Zone Impacts, see Section 503-2.02.
 - d. Approved Traffic Control Strategy memo, see Section 503-2.05(02),
 - e. Draft IHCP exception request, where required, see Section 503-3.02,
 - f. Detour Worksheet (Non-Interstate or Interstate), Design Manual Editable Documents Webpage, under Traffic Maintenance (MOT),
 - g. Crossover and Runaround Viability Worksheet, Design Manual Editable Documents Webpage, under Traffic Maintenance (MOT),
 - h. Contract Provision Strategies, see Section 503-2.06,
 - i. Temporary Signal Type Determination, Design Manual Editable Documents Webpage, under Traffic Maintenance (MOT),
 - j. Draft Programming Information for Portable Changeable Message Sign, Design Manual Editable Documents Webpage, under Traffic Maintenance (MOT)
 - k. Final design exception request,
 - l. Final mitigation measures, see Section 503-4.0.
17. Traffic Control Plan Checklist. See [Section 14-1.02\(03\)](#) for Traffic Control Plan Checklist information.
18. MSE Wall Design Review Checklist. If the project includes MSE walls, and the geotechnical soils investigations and the retaining wall plan sheets have been finalized, the relevant plan sheets and the completed MSE Wall Design Review checklist may be

submitted to the Geotechnical Engineering Division for review at MSEWallShopDrawings@indot.IN.gov at this stage. The checklist is available for download from the Department's [Design Manual Editable Documents](#), under Geotechnical.

14-2.04(09) Stage 3 Review Submission [Rev. Feb 2012, May 2013, Apr 2017, May 2017, Nov. 2017, May 2020, Feb. 2021, Mar. 2021, Jun. 2021, Dec.2021]

Plans should be approximately 95% complete at this stage.

For this submittal, finalize the plans and include all roadway, traffic, and bridge details, and check the computations.

For a project that requires only a Stage 3 Submission, all documentation required for Stages 1 through Final Right-of-Way Plans Preparation, if not previously submitted, must be included in the Stage 3 submittal. Documentation will include the abbreviated Engineer's Assessment, geotechnical report, and pavement-design approval.

If the project includes traffic signal(s), signing, or lighting details a separate set of plans should be submitted into ERMS for traffic review in accordance with Section 14-1.02(09).

Complete the following and review these elements for quality assurance.

1. Previous Reviews. Include the marked-up plans from the previous submittal with this submission.
2. Conformance. Review the plans for conformance with the Level One controlling design criteria listed in Section 40-8.02(01) and identify approval dates of design exceptions.
3. Pavement Design. Incorporate the final pavement design into the typical cross section and final quantities.
4. Computations and Quantities. Include the computations and quantities with this submission as follows:

- a. final approach drainage design;
 - b. superstructure design;
 - c. end bent or abutment design;
 - d. interior substructure design;
 - e. bridge-seat elevations;
 - f. screeds at copings, profile grade, each beam line, and each construction joint;
 - g. superstructure quantities;
 - h. end-bent or abutment quantities;
 - i. interior substructure quantities;
 - j. pavement, curb, sidewalks, and related quantities;
 - k. drainage-structure quantities;
 - l. riprap, sodding, and seeding quantities;
 - m. earthwork quantities;
 - n. traffic-related items and designs as discussed and revised from Field Check Plans;
 - o. traffic-maintenance quantities;
 - p. miscellaneous roadway quantities;
 - q. updated construction cost estimate;
 - r. completed special provisions; and
 - s. erosion- and sediment-control features design.
5. Reports. Ensure that the recommendations from the hearing comments, Geotechnical Report, or other reports regarding peat, hazardous waste, special wastes, etc., have been incorporated into the plans, specifications, and cost estimate.
6. Plans. The plans should be nearly complete at this stage and should include the following.
- a. Title and Index Sheets. Complete the Design Data block and update the index as necessary.

- b. Typical Cross Sections. Add the final pavement design information.
- c. Plan and Profile Sheets. Ensure that structure notations are completed; sodding, riprap, and paved side ditch locations are indicated; earthwork balances are shown; and removal items identified. Right-of-way station offsets from the final right-of-way plans should be incorporated.
- d. Details Sheets. Ensure that all details are completed and included with this submission. This includes details for the following:
- (1) reinforced-concrete bridge approach bill of materials and details;
 - (2) temporary erosion control;
 - (3) traffic-maintenance details; and
 - (4) traffic-design elements (e.g., intersections, signals, signing, or lighting).
- e. Bridge Sheets. Finalize the design for these sheets as follows.
- (1) Soil Borings sheet.
 - (2) Layout sheet. Ensure that the riprap and slopewall quantities are shown and the earthwork summary is completed.
 - (3) General Plan sheet.
 - (4) End Bent or Abutment Details.
 - (5) Interior Substructure Details.
 - (6) Superstructure Details.
- f. Tables. Complete all data tables including the following:
- (1) Bridge Summary Table;
 - (2) Structure Data Table;
 - (3) Approach Table;
 - (4) Underdrain Table;
 - (5) Paved Side Ditch and Sodding Table;

- (6) Guardrail Table;
- (7) Sign Summary Table; and
- (8) Curb Ramps and Sidewalks Table if not detailed elsewhere.

g. Cross Sections. Design information should be essentially complete. This includes final structure notations, earthwork areas and volumes, and benching areas and volumes.

7. Special Provisions and Special Provision Menus. Compile all USPs submitted via SharePoint into a single Word document and submit via ERMS. This is to aid the Design Reviewer in viewing a comprehensive Stage 3 submission and does not replace the SharePoint process. See Chapter 19 for additional information on the unique special provision submittal and review process.

Compile all completed contract-specific recurring special provisions into a single Word document.

Complete the unique and recurring special provision menus.

8. Level One Checklists and Design Computations. If there are no changes to the plans which affect Level One criteria since the prior submission, it is acceptable to copy the previous Level One Checklist and add a statement that no changes have been made to the plans that affect Level One criteria. The statement should be initialed and dated for the current submission.

The designer should submit a Level One Checklist, including computations for the mainline, each S-line, and each traffic-maintenance phase. The designer should include computations for the required intersection sight distance at each public road, including each local-service road or frontage road within the project limits. The designer should also submit documentation of the intersection sight distance provided at each public road. This requirement also applies to the traffic-maintenance phases.

9. Environmental Consultation Form.

10. Rule 5 Submission. If required and not previously submitted, submit in accordance with Section 9-1.02.

11. Bridge Load Rating. Bridge load rating requests should be submitted through the Load Rating Request Application (LRRRA), available through ITAP. Instructions for use are available for download from the [Bridge Design and Load Rating webpage](#), under Bridge Load Rating.

- a. Department-Owned Bridge. For both tradition design-bid-build and alternate procurement methods such as design-build, the Bridges Division Load Rating Engineer completes the load rating for a Department-owned bridge.

Traditional Project Development. Bridge load rating requests should be submitted through LRRRA. A separate set of bridge plans (excluding cross sections) should also be uploaded through the LRRRA.

If the analysis shows an unacceptable rating, a notification will be sent from the LRRRA denying the request. When a request is denied, design and plan revisions are required. A new request should be submitted with revised plans.

Alternate Procurement Project Development. Bridge Load Rating should be included as a hold point in the technical provisions. The bridge load rating should be requested through the LRRRA upon completion of the design plans. The load rating must be completed prior to the approval of structural member working drawings. Where working drawings are not required, the load rating must be complete prior to work being performed on bridge elements.

- b. Local Public Agency (LPA) Bridge. A load rating request is not required for an LPA-owned bridge. The LPA is responsible for the load rating of an LPA-owned bridge in accordance with the INDOT [Bridge Inspection Manual](#). An INDOT-certified Load Rating Engineer (LRE) must complete the load rating.
- c. Bridge-Length Structure Under Fill. A load rating request is not required for a precast bridge-length three-sided structure or box structure. Load rating for these structures is performed in accordance with the *Standard Specifications* as part of the working drawing submission process. A copy of the load rating submitted with the working drawings should be forwarded to the Department's Load Rating Engineer.

12. INDOT All Project Commitments Report. This should include all known resolutions.

13. Foundation Review Form. This form is available for download from the Department's [Design Manual Editable Documents](#), under Bridges.

14. MSE Wall Design Review Checklist. If the project includes MSE walls and the retaining wall plans were not finalized and submitted at Stage 2 along with the completed MSE Wall Design Review checklist (or the Stage 2 review comments have not been addressed to the satisfaction of Geotechnical Engineering Division), the relevant plan sheets and the completed MSE Wall Design Review checklist are required to be submitted to the Geotechnical Engineering Division for review at MSEWallShopDrawings@indot.IN.gov. The checklist is available for download from the Department's [Design Manual Editable Documents](#), under Geotechnical.

15. Traffic Control Plan Checklist. See [Section 14-1.02\(03\)](#) for Traffic Control Plan Checklist information.

16. Final Approved IHCP Request, if required. See Section 503-3.02.

17. Final TMP Report for Significant Projects. See Section 503-2.0

14-2.05(05) Stage 3 Review Submission (Final Plans) [Rev. Mar. 2016, Sep. 2021, Dec. 2021]

The following should be reviewed in accordance with quality assurance procedures and included in this submission. Information required for the Stage 2 (Preliminary Plans) Submission should be included in this submission, if not previously submitted. If the project includes traffic signal(s), signing, or lighting details a separate set of plans should be submitted into ERMS for traffic review in accordance with Section 14-1.02(09).

1. Transmittal Letter. Identify any unique circumstances for the submittal, e.g. omitted items or items that are not applicable, the Responsible Person to receive the evaluation scores as well as any subconsultants and their work responsibilities.
2. Response to Comments. Include the Stage 2 comment letter and marked up plans with responses to all comments. These items should be combined into a single document.
3. Plan Sheets. Ensure plan sheets required in previous submittals are included as applicable. The plans should include specific measures proposed by the Railroads, Utilities,

Environmental, Geotechnical, or Hydraulics offices. The following additional sheets should be included as applicable.

- a. Soil Borings Sheets.
 - b. Traffic Maintenance Details. Finalized MOT details.
 - c. Detail Sheets. All necessary plans details required to adequately define the required repairs. Details could include, but not be limited to, floor details, superstructure details, substructure details, railing details, reinforced-concrete bridge approach details, and temporary erosion- and sediment-control measure details.
 - d. Tables. Include a bridge summary, guardrail summary and other tables as applicable.
4. Quantity Calculations. Finalize all quantities. Designer and checker initials and date should be shown on each sheet.
 5. Design Computations. Finalize design computations. Designer and checker initials and date should be shown on each sheet. Include the Hydraulics Approval and Scour memos from the Office of Hydraulics, where applicable.
 6. Cost Estimate. Conduct a detailed review to ensure that all necessary pay items have been included.
 7. Special Provisions and Special Provision Menus. Compile all USPs submitted via SharePoint into a single Word document and submit via ERMS. This is to aid the Design Reviewer in viewing a comprehensive Stage 3 submission and does not replace the SharePoint process. See Chapter 19 for additional information on the USP submittal and review process.

Compile all completed contract-specific recurring special provisions into a single Word document.

Complete the unique and recurring special provision menus.

8. Geotechnical Report. Include the report or indicate its location within ERMS in the transmittal letter.
9. MSE Wall Design Review Checklist. If the project included MSE walls, the relevant plan sheets and the completed MSE Wall Design Review checklist are required to be submitted to the Geotechnical Services Division for review at

MSEWallShopDrawings@indot.IN.gov. The checklist is available for download from the Department's [Design Manual Editable Documents](#), under Geotechnical.

10. Geotechnical Review of Final Check Prints Form. This form is available for download from the Department's [Design Manual Editable Documents](#), under Geotechnical. For projects for which the geotechnical investigation was performed by a consultant, note on the Transmittal Letter that the plans and the form have been transmitted to the geotechnical consultant. For projects for which the geotechnical investigation has been performed by the Department, the form, with plans, should be uploaded into ERMS for review by the Office of Geotechnical Services.
11. Foundation Review Form. This form is available for download from the Department's [Design Manual Editable Documents](#), under Bridges.
12. Environmental Document. Indicate the status or the location within ERMS in the transmittal letter.
13. Environmental Consultation Form. This form is available for download from the Department's [Design Manual Editable Documents](#), under Environmental.
14. Permits. Approved permits do not need to be submitted for review, but all necessary permits should be applied for. The status of permits should be indicated on the Environmental Consultation Form.
15. All Project Commitments Report. The All Project Commitments Report is generated from the Commitments Database. Information on accessing the Commitments Database and other project commitments documents are available at <http://www.in.gov/indot/2731.htm>. All know resolutions should be included.
16. Initiate Stormwater Quality Manager Determination. The designer should Provide initial Stormwater Quality Manager level recommendation on Transmittal Letter with brief explanation. The SWQM level starts at Level 1 and will be elevated to Level 2 based on meeting either the primary or secondary categories. SWQM Level determination guidance is available from the Department's [Design Manual Editable Documents](#), under Environmental.
17. Level One Controlling Criteria Checklist and Design Computations. For a Preventive Maintenance project, a Level One controlling criteria checklist is only required for MOT. ADA and Bridge Railing Test Level should be addressed in accordance with Section 412-3.01. For Rehabilitation projects, the checklist is required for both the proposed condition and the MOT. If there are no changes to the plans which affect Level One controlling criteria since the prior submission, it is acceptable to submit the previous checklist and

initial and date next to the statement that no changes have been made to the plans that affect Level One controlling criteria. See Section 40-8.02. A checklist should be prepared for each phase of the proposed MOT.

18. Load Rating. See Section 14-2.04(09)
19. Proprietary Materials. Include approved request for the use of proprietary materials. See Chapter 17. Approved proprietary material justification is required for proprietary materials that have federal participation.
20. Asbestos Report.
21. Traffic Control Plan Checklist. See [Section 14-1.02\(03\)](#) for Traffic Control Plan Checklist information.
22. Final Approved IHCP Request, if required. See Section 503-3.02.
23. Final TMP Report for Significant Projects. See Section 503-2.0

Chapter 402 Revisions

402-6.02(02) Alignment [Rev. Mar. 2017, Dec. 2021]

The horizontal and vertical alignment will be determined for the overall roadway within the project limits, and the bridge will be designed consistent with the roadway alignment. See Chapter [53](#) for geometric-design criteria. The desirable horizontal and vertical alignment objectives are as follows.

1. Grade. A minimum longitudinal grade of 0.5% on the bridge is desirable. A flatter grade will be permitted where it is not physically or economically desirable to satisfy this criterion.
2. Vertical Clearance. The vertical clearance requirements are shown in Figure [402-6J](#). This clearance shall be provided for the elevation and alignment of the overhead structure. The vertical clearance is determined at the low-steel or -concrete member elevation. Figures [402-6A](#), [402-6B](#), and [402-6C](#) illustrate where the clearance is measured. Clearance shall be maintained across both the traveled way and the shoulders. The same minimum vertical clearance in the traveled way and shoulders is not required to be maintained in the clear zone. However, a separate minimum vertical clearance is often necessary within the clear zone. For economy, the minimum vertical clearance shall not be exceeded by more than 6 in. unless project constraints require a higher clearance.

Consideration of the vertical and horizontal clearance during construction phases shall be considered in setting the profile of the bridge. See Chapter [83](#) for requirements during construction.

3. End Bent. The end-bent configuration impacts the required structure length and shall be accounted for in the sizing of the structure. The following will apply.
 - a. The clearance from the top of the berm to the bottom of the superstructure shall be at least 6 in., with a maximum of 1'-8". The minimum berm width is 3 ft. See Figure [402-6K](#).
 - b. Wingwalls will be required for each beam structure.
 - c. The spillslope for a water crossing is limited to a maximum of 2:1, except for a structure located within the backwaters of the Ohio River, where the spillslope is 3:1. For an overpass structure, the required crossed-roadway-section clear-zone width shall be considered in the setting of spill slopes.
 - d. Where utilizing an MSE retaining wall at an end bent, a minimum distance of 4 times the diameter of pile is required between the back of the wall panel and the center of the pile. The need for pile sleeves will be determined by the Geotechnical Engineer of Record. *LRFD* 11.10.10 provides additional information regarding the placement of obstructions in the reinforced soil zone.

Chapter 410 Revisions

410-5.01(06) Design Criteria [Rev. May 2012, May 2013, Mar. 2017, Feb. 2021, Dec. 2021]

The recommend minimum resistance strengths with respect to failure modes are as follows.

1. External Stability. Sliding eccentricity, e , at base, plus bearing capacity, deep-seated stability, and seismic stability shall be checked based on *LRFD* 11.10.5.

The design height of the wall, Z , shall be measured from the theoretical top of the leveling pad to a point above the top of the wall as calculated from the formula as follows:

$$Z = H + L \tan \beta$$

Where:

- H = height of the wall from the theoretical top of the leveling pad to the top of the coping,
 L = width of the reinforced zone, and
 β = surcharge slope angle as measured from the top of the coping.

See Figure [410-5\(0\)A](#).

2. Internal Stability. Pullout resistance shall be checked based on *LRFD* 11.10.6.
 - a. Design Limits and Wall Height. The length and height required to satisfy the project's geometric requirements shall be established to determine the type of structure and external loading configurations.
 - b. Length of Ground Reinforcement. The minimum reinforcement length for an MSE wall is the greater of $0.7H$ or 8 ft. A greater length may be required for a structure subject to surcharge loads, or if the factored MSE-wall loads are more than the factored bearing resistance.
 - c. External Loads. The external loads can be surcharges required by the geometry, adjoining footing loads, line loads from traffic, traffic impact loads, or sound-barrier loads. Traffic live loads and impact loads are applicable where the traffic lane is located horizontally from the face of the wall within a distance of less than one half the wall height.

3. Seismic Activity. Due to an MSE wall's flexibility, it is resistant to dynamic forces developed during a seismic event. See the *LRFD Bridge Design Specifications* for seismic-design considerations.
4. Protection of MSE Wall Against Collision. An MSE-wall bridge abutment placed adjacent to a roadway shall be checked for vehicle-collision forces as described in Section 403-3.07.
5. Acute Angles. Acute angles should be avoided because of construction difficulties, e.g. compaction in corners and placement of reinforcement. Where two intersecting walls form an enclosed angle, the angle is to be greater than or equal to 70 degrees.
6. Wall Curves. Sharp curves should be avoided in the wall layout. The curvature of a wall will impact the size of panel that can be provided. Typically, a 10-ft wide panel can accommodate a radius of 100 ft. and a 5-ft wide panel can accommodate a radius of 50 ft.
7. Utilities. Utilities should not be placed through and under the reinforced zone. Where utility placement is unavoidable, future access must be provided to the utility without disrupting the reinforcement. The breakage or rupture of the utility must not have a detrimental effect on the stability of the MSE wall.
8. Culverts. Culverts passing through and under the wall should be avoided. If avoidance is impossible, then other measures such as slip joints must be provided. Culverts passing through the MSE Walls are typically rigid and the MSE wall facing is flexible and moves. This over time opens up joints at the interfaces allowing backfill leakage. Slip joints provides the barrier to avoid this situation. Culvert at skew should not be passing through the wall unless it can be shown that they will not interfere with the MSE wall reinforcement.

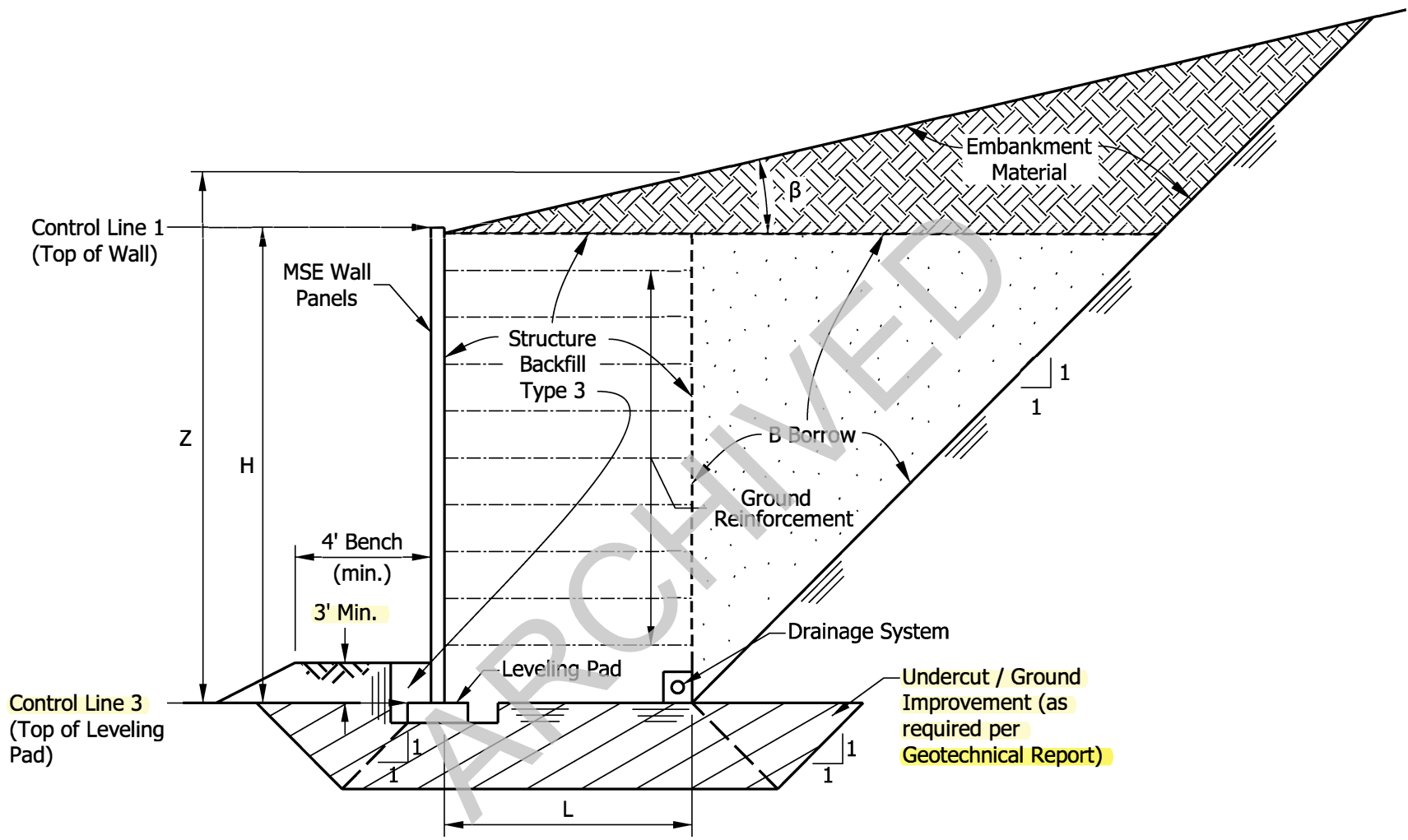

MSE RETAINING WALL EARTHWORK QUANTITIES LIMITS

Figure 17-5C

[Rev. Dec. 2021]

NOTE:

Coarse aggregate and 6" end-bent drain pipe are not required to be specified separately for an end bent placed behind an MSE Wall.

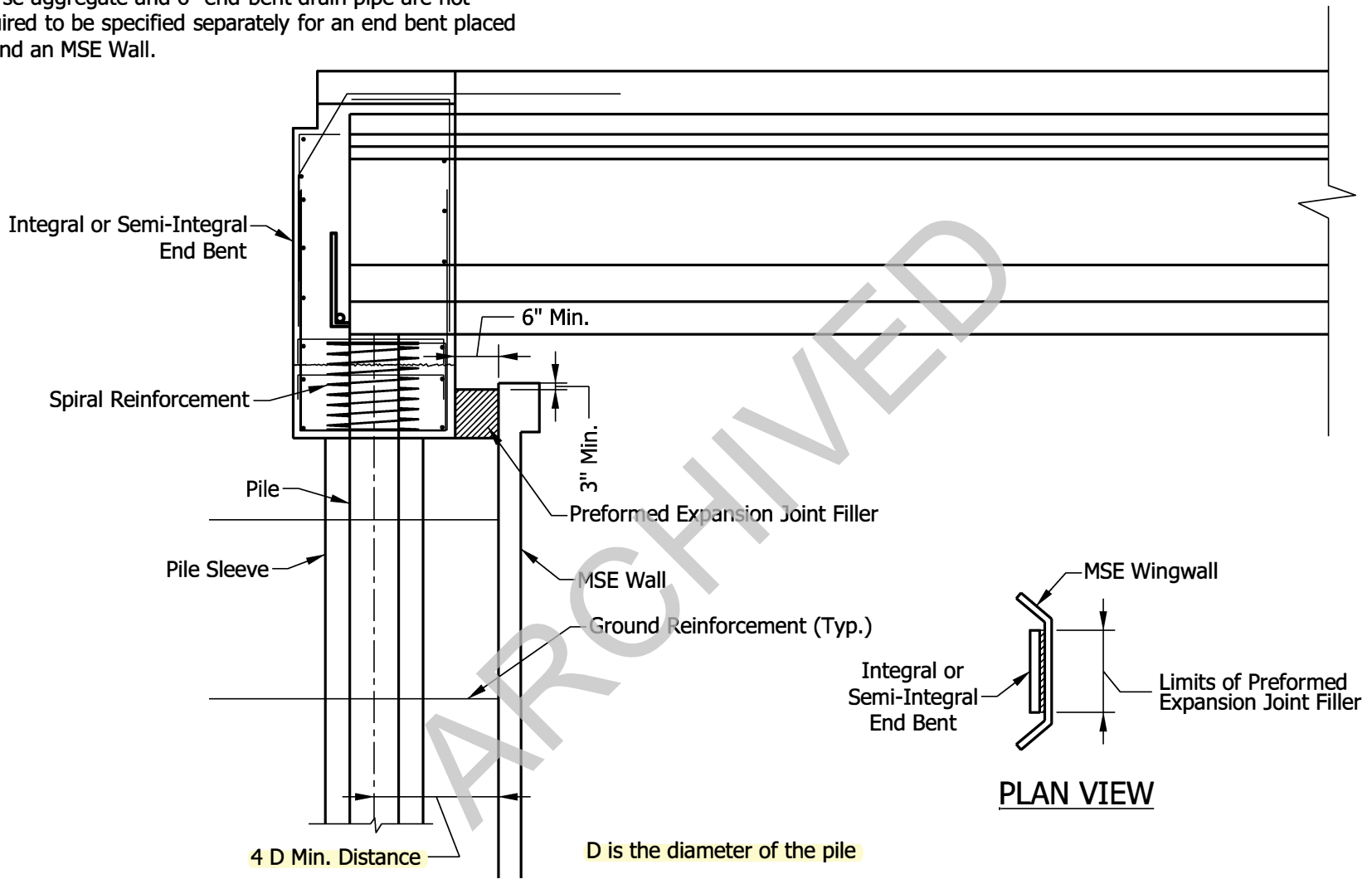

END BENT PLACED BEHIND MSE WALL

**Figure 409-2G
(Page 1 of 3)**

[Rev. Apr. 2021, Dec. 2021]

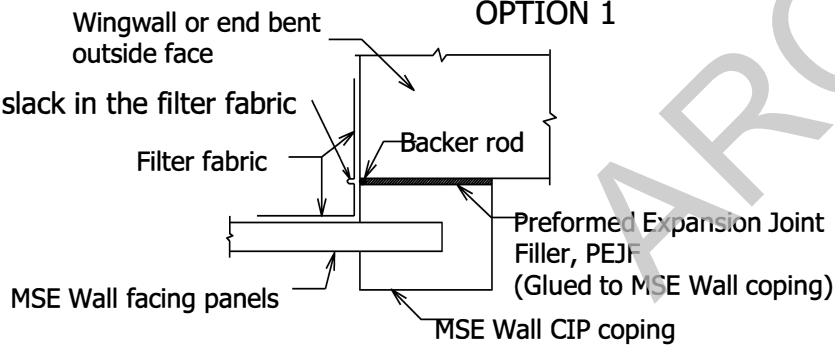
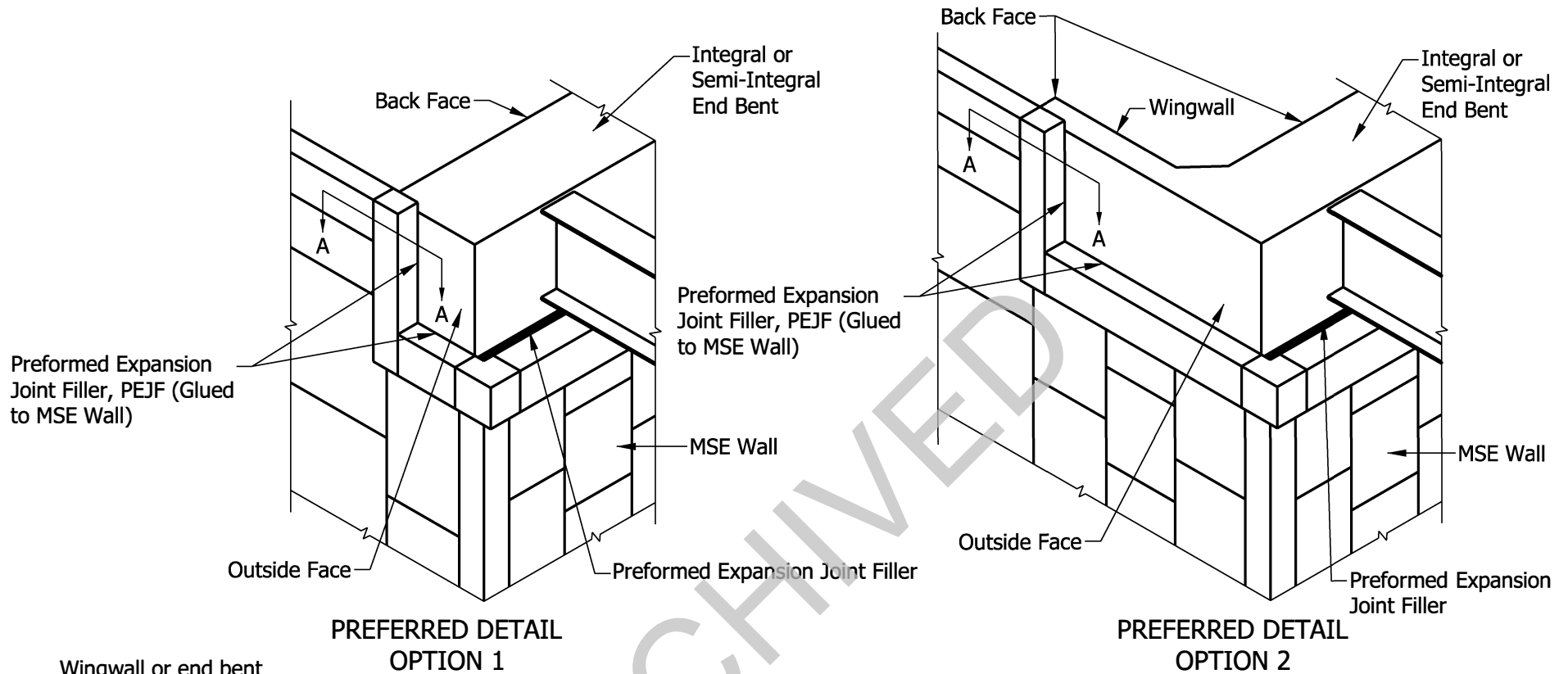

SECTION A-A END BENT PLACED BEHIND MSE WALL

NOTE:

Where an MSE is placed parallel to the bridge approach roadway, it should be placed adjacent the outside face of the end bent or wingwall, but not cast against it. Sufficient clearance is needed to accommodate the thermal movement of the end bent. The MSE wall should not be placed abutting the back face of the end bent or wingwall. Preformed Expansion Joint Filler, PEJF should be placed between MSE wall and outside face of the end bent or wingwall, PEJF should be glued to MSE wall.

Figure 409-2G

(Page 2 of 3)

[Rev. Apr. 2021, Dec. 2021]

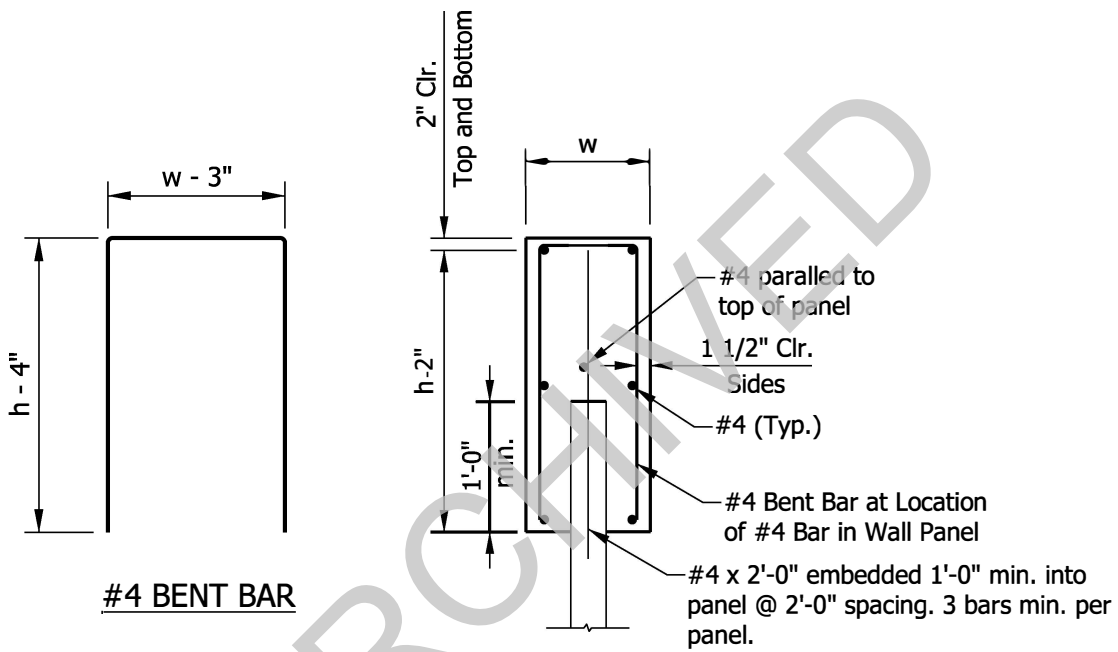

MSE Wall CIP Coping

Figure 409-2G
(Page 3 of 3)

[Rev. Dec. 2021]

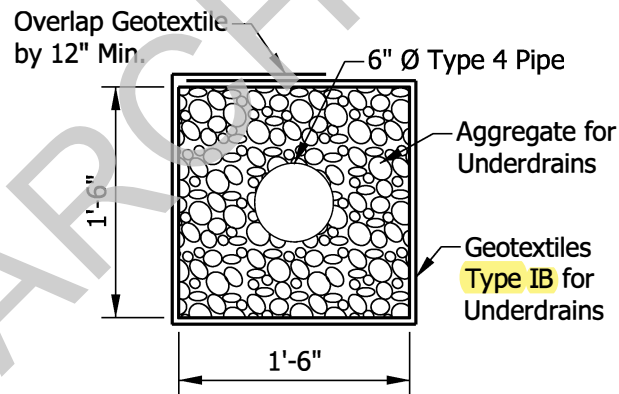
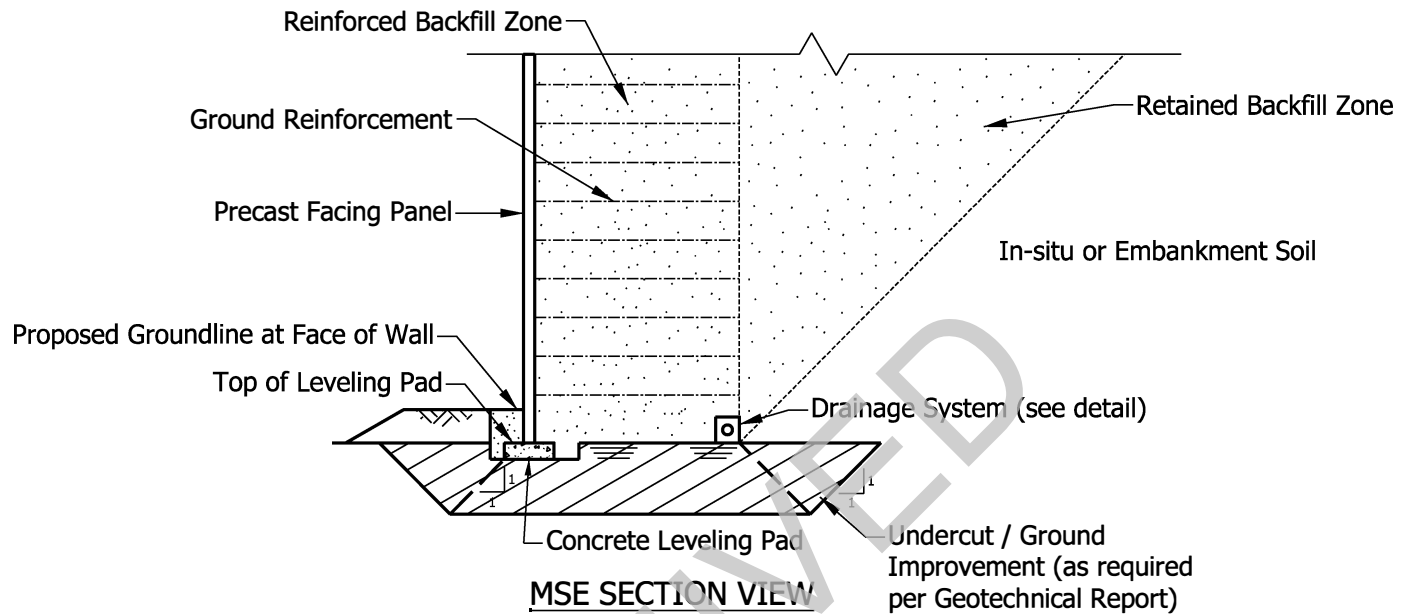

TYPICAL MSE WALL CROSS SECTION

Figure 410-5(0)C

[Rev. Feb. 2021, Dec. 2021]

MSE WALL DESIGN REVIEW CHECKLIST

INSTRUCTIONS

This checklist should be completed by the Engineer of Record (EOR) and submitted to the Geotechnical Services Division for review at MSEWallShopDrawings@indot.IN.gov, in accordance with IDM Chapter 14.

A link to frequently used abbreviations and acronyms is provided [here](#).

The following tables should be filled out by the party listed in parenthesis.

PROJECT INFORMATION (EOR)

Contract No.	
Des. No. (associated with MSE wall details)	
Route(s)	
Feature Crossed (if applicable)	

DESIGNER (EOR) and GEOTECHNICAL EOR INFORMATION

Name of EOR	
EOR Consulting Firm or INDOT Location	
Name of Geotechnical EOR	
Geotechnical EOR Consulting Firm or INDOT Location	

INDOT GEOTECHNICAL REVIEWER INFORMATION (Geotechnical Engineering Division)

Name	
Date Received	
Date Returned to EOR	
Is a resubmittal required?	

NOTES FOR CHECKLIST

1. The following information/material should be referenced while completing the checklist:
 - a. Project documents (final plan set, *Standard Specifications*, Standard Drawings, special provisions, project geotechnical report)
 - b. FHWA/NHI manual ("Mechanically Stabilized Earth Walls and Reinforced Soil Slopes," Publications. FHWA NHI-10-024 Vol I and NHI-10-025 Vol II, December 2009; Authors: Ryan R. Berg, Barry R. Christopher and Naresh C. Samtani)
 - c. Applicable version of AASHTO *LRFD Bridge Design Specifications*, including interims referenced on the plans.

2. Each question must have a "Yes", "No" or "N/A" box checked. Add any pertinent project specific questions to the checklist under "Place comments here. If NO or N/A is checked comments are required," as necessary. Additional sheets may be used if more space is required.

3. The documents listed under the "Reference" column in the checklist are not intended to be a complete list of documents. Rather, the most common documents are listed where guidance/information related to the question in the checklist may be found. More stringent criteria may exist in other project documents (e.g., special provisions, etc.) that may be relevant to a given question. In such an event, the governing document should be noted in the "Comments/Action Required" column of the checklist.

CHECKLIST

I. INITIAL FEASIBILITY REVIEW FOR PROJECT SITE				
QUESTION	REFERENCE	YES	NO	N/A
1. Has the MSE Wall been submitted to INDOT Geotechnical Services Division for evaluation of suitability? [place date of submittal in comments below]	IDM Ch. 14	<input type="checkbox"/>	<input type="checkbox"/>	<input type="checkbox"/>
Place comments here. If NO or N/A is checked comments are required.				
II. DESIGN CRITERIA				
QUESTION	REFERENCE	YES	NO	N/A
1. Are all acute angles greater than 70 degrees?	IDM 410-5.01(06)	<input type="checkbox"/>	<input type="checkbox"/>	<input type="checkbox"/>
Place comments here. If NO or N/A is checked comments are required.				
2. Are the radii of curves in the horizontal alignment of the wall greater than 100 ft for standard 10 ft wide panels, and greater than 50 ft for 5 ft wide panels?	IDM 410-5.01(06)	<input type="checkbox"/>	<input type="checkbox"/>	<input type="checkbox"/>
Place comments here. If NO or N/A is checked comments are required.				

II. DESIGN CRITERIA (Continued)

QUESTION	REFERENCE	YES	NO	N/A
3. Are utilities located within the reinforced zone? Where utility placement in the reinforced zone is unavoidable, future access must be provided to the utility without disrupting the reinforcement.	IDM 410-5.01(06)	<input type="checkbox"/>	<input type="checkbox"/>	<input type="checkbox"/>
Place comments here. If NO or N/A is checked comments are required.				
4. Are utilities located under the wall? Where utility placement under the reinforced zone is unavoidable, future access must be provided to the utility without disrupting the reinforcement.	IDM 410-5.01(06)	<input type="checkbox"/>	<input type="checkbox"/>	<input type="checkbox"/>
Place comments here. If NO or N/A is checked comments are required.				
5. Are culverts located within the reinforced zone? If so, slip joints should be provided. If the culvert is at skew, the skew should not affect the placement of reinforcement as per IDM.	IDM 410-5.01(06)	<input type="checkbox"/>	<input type="checkbox"/>	<input type="checkbox"/>
Place comments here. If NO or N/A is checked comments are required.				
6. Is the wall embedment per LRFD, but not less than 3 ft from final grade to top of leveling pad, unless founded on rock.?	LRFD 11.10.2.2, Spec 731.03 IDM 410-5.01(05)	<input type="checkbox"/>	<input type="checkbox"/>	<input type="checkbox"/>
Place comments here. If NO or N/A is checked comments are required.				
7. Is the top of leveling pad at least 1 ft above ordinary high water and groundwater elevation?	IDM 410-5.01(05)	<input type="checkbox"/>	<input type="checkbox"/>	<input type="checkbox"/>
Place comments here. If NO or N/A is checked comments are required.				
8. Is coarse aggregate No. 8 used behind the wall instead of structure backfill up to the Q100 high-water elevation?	IDM 410-5.01(05)	<input type="checkbox"/>	<input type="checkbox"/>	<input type="checkbox"/>
Place comments here. If NO or N/A is checked comments are required.				
9. Has a horizontal bench with a min. width of 4 ft been provided in front of walls where the back slope is steeper than 4H:1V?	IDM 410-55.01(05), Spec 731.03	<input type="checkbox"/>	<input type="checkbox"/>	<input type="checkbox"/>
Place comments here. If NO or N/A is checked comments are required.				

II. DESIGN CRITERIA (Continued)

QUESTION	REFERENCE	YES	NO	N/A
10. Is the embedment and bench day-lighted and ripped??	Spec 731.03	<input type="checkbox"/>	<input type="checkbox"/>	<input type="checkbox"/>
Place comments here. If NO or N/A is checked comments are required.				
11. Does the MSE wall drainage system show the required drain outlets?	IDM 410-5.01(07)	<input type="checkbox"/>	<input type="checkbox"/>	<input type="checkbox"/>
Place comments here. If NO or N/A is checked comments are required.				
12. Has moment slab been placed adjacent to the MSE wall coping, and not on top of the coping?	Standard Drawings Series E 706-MSRW	<input type="checkbox"/>	<input type="checkbox"/>	<input type="checkbox"/>
Place comments here. If NO or N/A is checked comments are required.				
13. Has guardrail been located so that the posts will be located outside the limits of the MSE wall reinforced zone?	IDM 410-5.01(05)	<input type="checkbox"/>	<input type="checkbox"/>	<input type="checkbox"/>
Place comments here. If NO or N/A is checked comments are required.				
14. Have the piles been located a minimum of 4 times the diameter of pile between the back of the wall panels and the center of the piles?	IDM 402-6.02(02)	<input type="checkbox"/>	<input type="checkbox"/>	<input type="checkbox"/>
Place comments here. If NO or N/A is checked comments are required.				
15. Has a minimum of 6 in. been provided between the MSE coping and face of end bent.?	IDM Fig. 409-2G	<input type="checkbox"/>	<input type="checkbox"/>	<input type="checkbox"/>
Place comments here. If NO or N/A is checked comments are required.				
16. Have integral end bents and semi-integral end bent diaphragms been isolated from the MSE wall system for calculated thermal movements?	IDM Fig. 409-2G	<input type="checkbox"/>	<input type="checkbox"/>	<input type="checkbox"/>
Place comments here. If NO or N/A is checked comments are required.				

III. PLAN DETAILS

QUESTION	REFERENCE	YES	NO	N/A
1. Have the following been shown in the Elevation View?				
a. Wall envelope including control lines 1, 2, and 3	IDM 410-5.01(07), PGR	<input type="checkbox"/>	<input type="checkbox"/>	<input type="checkbox"/>
b. Minimum embedment from top of leveling pad to the final ground line		<input type="checkbox"/>	<input type="checkbox"/>	<input type="checkbox"/>
c. Undercut and soil improvement requirements		<input type="checkbox"/>	<input type="checkbox"/>	<input type="checkbox"/>
d. Leveling pad steps level and in 2.5 ft increments		<input type="checkbox"/>	<input type="checkbox"/>	<input type="checkbox"/>
e. Obstructions that protrude through the wall face		<input type="checkbox"/>	<input type="checkbox"/>	<input type="checkbox"/>
f. Obstruction, such as utilities, pipes, or culverts, placed below the leveling pad		<input type="checkbox"/>	<input type="checkbox"/>	<input type="checkbox"/>
g. Factored bearing resistance from Geotechnical Report		<input type="checkbox"/>	<input type="checkbox"/>	<input type="checkbox"/>

Place comments here. If NO or N/A is checked comments are required.

2. Have the following been shown in the Plan View?				
a. Obstructions within reinforced or retained backfill zones, including station and offset to the back of wall panel. [due diligence is expected to avoid placing obstructions within the reinforced backfill zone]	IDM 410-5.01(07), PGR	<input type="checkbox"/>	<input type="checkbox"/>	<input type="checkbox"/>
b. Station and offset relative to survey centerline to the back of the wall panel and all such information for turn point locations		<input type="checkbox"/>	<input type="checkbox"/>	<input type="checkbox"/>
c. Flow direction arrows for surface water coming from the bridge, ramp and/or road above the MSE wall and being directed away from the reinforced backfill area of the wall		<input type="checkbox"/>	<input type="checkbox"/>	<input type="checkbox"/>
d. Wall construction limits relative to temporary and permanent ROW		<input type="checkbox"/>	<input type="checkbox"/>	<input type="checkbox"/>
e. Internal wall drainage details with outlet locations		<input type="checkbox"/>	<input type="checkbox"/>	<input type="checkbox"/>

Place comments here. If NO or N/A is checked comments are required.

III. PLAN DETAILS (Continued)

QUESTION	REFERENCE	YES	NO	N/A
3. Have the following been shown in the Section Views?				
a. Estimated dimensions of reinforced and retained backfill	IDM 410-5.01(07), PGR	<input type="checkbox"/>	<input type="checkbox"/>	<input type="checkbox"/>
b. Slope of ground above the top and in front of wall		<input type="checkbox"/>	<input type="checkbox"/>	<input type="checkbox"/>
c. Distance between the back of the wall face and piles or pile sleeves		<input type="checkbox"/>	<input type="checkbox"/>	<input type="checkbox"/>
d. Undercut and soil improvement details		<input type="checkbox"/>	<input type="checkbox"/>	<input type="checkbox"/>
Place comments here. If NO or N/A is checked comments are required.				
4. Have the following Special Wall Details been shown?				
a. Architectural treatments	IDM 410-5.01(07), PGR	<input type="checkbox"/>	<input type="checkbox"/>	<input type="checkbox"/>
b. Special facing elements where connecting to existing wall systems		<input type="checkbox"/>	<input type="checkbox"/>	<input type="checkbox"/>
c. Tiered walls detail in accordance with project criteria, including bench widths, aesthetics within benches, etc.		<input type="checkbox"/>	<input type="checkbox"/>	<input type="checkbox"/>
d. Instrumentation details		<input type="checkbox"/>	<input type="checkbox"/>	<input type="checkbox"/>
Place comments here. If NO or N/A is checked comments are required.				

ARCHIVED

ABBREVIATIONS / ACRONYMS

Construction Plans	Final plan set for the project as advertised, with all associated revisions.
EOR	Engineer of Record. Professional Engineer who stamped the construction plans
FHWA	Federal Highway Administration
Geotechnical EOR	Geotechnical engineer (in charge of the geotechnical investigation)
IDM	<i>Indiana Design Manual</i> https://www.in.gov/indot/design_manual/design_manual_2013.htm including INDOT Design Memorandum No. 17-03 available at https://www.in.gov/indot/files/17-03MSEwalls.pdf
LRFD	<i>AASHTO LRFD Bridge Design Specifications, including interims referenced on the plans.</i>
PGR	Project Geotechnical Report
Spec	INDOT <i>Standard Specifications</i> and any applicable special provisions (refer to contract documents for applicable spec year)
USP	Project specific unique special provision